



C161

Soft Serve Freezer

Compact Twin Twist

Features

Offer all the popular soft serve variations from low or non-fat ice creams to custard, yogurt and sorbet. Serve two separate soft serve flavors, or an equal combination of both in a twist.

Freezing Cylinder

Two, 1.5 quart (1.4 liter).

Mix Hopper

Two, 8 quart (7.6 liter). Separate hopper refrigeration (SHR) maintains mix below 41°F (5°C) in Auto and Standby modes.

Indicator Lights

The Mix Low light alerts the operator to add mix. Audible alarm may be enabled to sound when mix is low.

Electronic Controls

Finished product quality is monitored by Softech™ controls that measure viscosity.

Standby

During long no-use periods, the standby feature maintains safe product temperatures in the mix hopper and freezing cylinder.

Air Filter

Easily removable, cleanable air filter helps keep condenser clean for optimal refrigeration system performance.

Door Interlock System

Protects the operator from injury as the beater will not operate without the dispensing door in place.

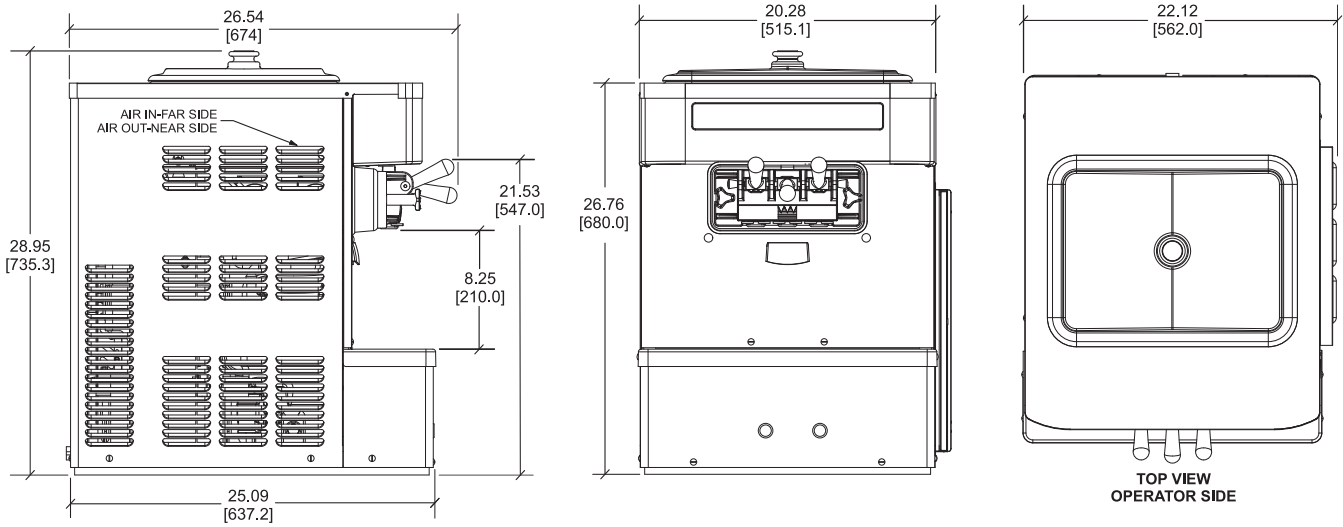

FIGURES IN BRACKETS INDICATE MILLIMETERS / DECIMAL AND FRACTIONAL DIMENSIONS EQUAL TO (PLUS OR MINUS 1/16 INCH [1.5mm]).
DRAWING IS TO BE USED FOR REFERENCE ONLY - DO NOT USE FOR STORE CONSTRUCTION LAYOUT.

Weights	lbs.	kgs.
Net	305	138.3
Crated	350	158.8
Volume	cu. ft.	cu. m.
	22.3	0.63
Dimensions	in.	mm.
Width	22-1/8	562
Depth	25-1/8	638
Height	29	737
Electrical	Total Amps	Poles(P) Wires(W)
208-230/60/1 Air	12	6-15P
220-240/50/1 Air	10	----

Specifications

Electrical

One dedicated electrical connection is required. See the Electrical chart for the proper electrical requirements. Manufactured to be cord connected. Consult the international Taylor distributor for cord & receptacle specifications for 50 Hz. equipment.

Beater Motor

Two, 0.5 HP

Refrigeration System

One, 3,500 BTU/hr compressor (nominal rating). R404A.
Separate Hopper Refrigeration (SHR), One, 400 BTU/hr. R134a.
(Actual BTUs will vary based on application.)

Air Cooled

Minimum Clearance: 6" (152 mm) on left and right, and 0" in the rear.
Minimum air clearances must be met to assure adequate air flow for optimum performance.

Options

- Cone Dispenser
- Legs - [increase height of unit by 4-1/4" (108 mm)]

This unit may be manufactured in other electrical characteristics and may have additional regulatory agency approvals. Consult the local Taylor Distributor for other electrical characteristics and agency approvals based on specific electrical and country requirements.

(For exact electrical information and approval marks, always refer to the data label of the unit.)

Continuing research results in steady improvements; therefore, these specifications are subject to change without notice.

Bidding Specs

Electrical: Volt _____ Hz _____ ph _____

Neutral: Yes No **Cooling:** Air Water NA

Options: _____

Authorized Taylor Distributor



750 N. Blackhawk Blvd.
Rockton, Illinois 61072
www.taylor-company.com
086028-ADV 4/17