



# C708

## Soft Serve Freezer

Single Flavor, Pump, Heat Treatment

### Features

Offer all the popular soft serve variations from low- to non-fat ice creams or yogurt.

#### Heat Treatment System

Provides a daily heating and cooling cycle to safely maintain dairy products up to 28 days before a complete disassembly and cleaning is required.

#### Freezing Cylinder

One, 3.4 quart (3.2 liter).

#### Mix Hopper

One, 20 quart (18.9 liter). Refrigerated to maintain mix below 41°F (5°C) in Auto and Standby modes. Simplified air/mix pump delivers the precise amount of air and mix to the freezing cylinder, and reduces operator parts.

#### Indicator Lights

Mix Low light alerts the operator to add mix. When the Mix Out light flashes, the unit automatically goes into Standby mode to prevent damage.

#### Touchscreen Controls

Microprocessor touch controls are embedded in durable tempered glass panel. Multiple languages are selectable. Viscosity is continually measured to dispense soft serve desserts. Soft lock out features improve reliability. Temperatures in the hopper or freezing cylinder may be displayed at any point of operation. History of temperatures and times during the last 366 heat cycles may be viewed from the fluorescent display.

#### Standby

During long no-use periods, the standby feature maintains safe product temperatures in the mix hopper and freezing cylinder.

#### Door Interlock System

Protects the operator from injury as the beater will not operate without the dispensing door in place.



**Optional Cart with front opening door**



**Optional Cart with rear door for front mount syrup rail**



**Optional Top Air Discharge Chute**



**Simplified Pump**

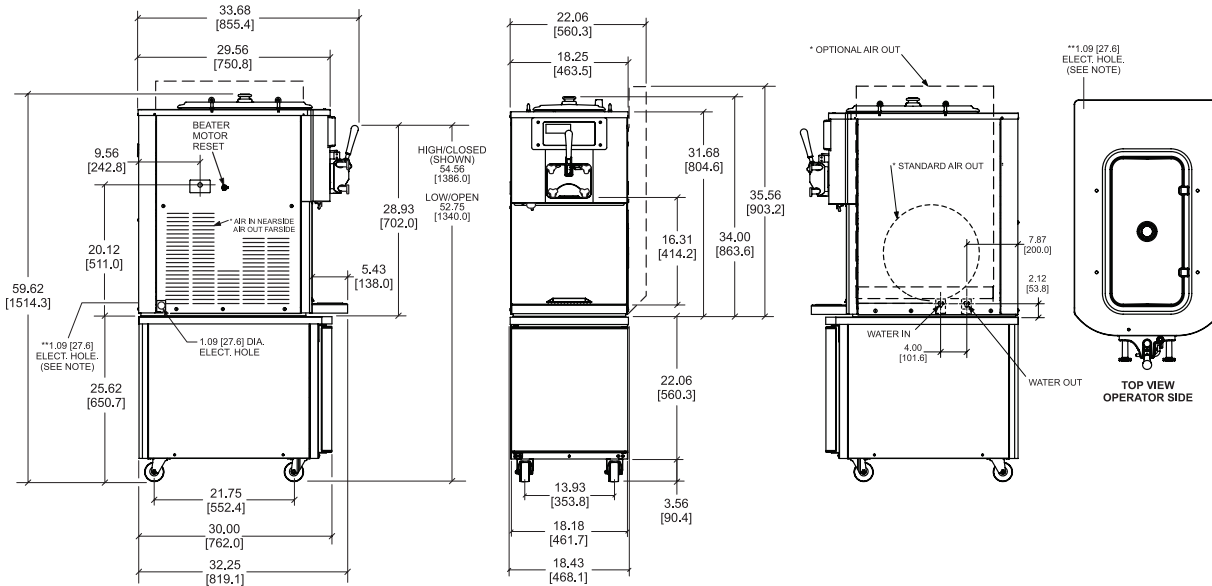

NOTE: \* AIR COOLED ONLY / \*\*1.09 [27.6] ELECTRICAL HOLE AVAILABLE FOR TOP AIR DISCHARGE OR WATER COOLED UNITS ONLY. FIGURES IN BRACKETS INDICATE MILLIMETERS / DECIMAL AND FRACTIONAL DIMENSIONS EQUAL TO ( PLUS OR MINUS 1/16 INCH [1.5mm] ).

Weights	lb.	kg
Net	425	192.8
Crated	471	213.6

\*For reference only

	cu. ft.	cu. m
Volume	35.0	0.99

Dimensions	in.	mm
Width	18-1/4	464
Depth	32-1/4	820
Height	34	864
Counter Clearance	---	---

\*Designed to rest on a plastic pad directly on the counter top or optional cart

Electrical	Maximum Fuse Size	Minimum Circuit Ampacity	Poles (P) Wires (W)
208-230/60/1 Air	25	21	2P 3W
208-230/60/1 Water	25	21	2P 3W
208-230/60/3 Air	20	15	3P 4W
208-230/60/3 Water	15	14	3P 4W
220-240/50/1 Air	25	19	2P 3W
380-415/50/3N~ Air	10	8	4P 5W

This unit may be manufactured with other electrical characteristics and may have additional regulatory agency approvals. Consult the local Taylor distributor for other electrical characteristics and agency approvals based on specific electrical and country requirements.

(For exact electrical information, approval marks, and refrigerant, always refer to the data label of the unit.)

**Continuing research results in steady improvements. Therefore, these specifications are subject to change without notice.**

**Bidding Specs**

Electrical: Volt \_\_\_\_\_ Hz \_\_\_\_\_ ph \_\_\_\_\_  
 Neutral: Yes No      Cooling: Air Water NA

**Options:**

All options may not be available in combination with others or with all electrical or cooling configurations. Please consult your local Taylor distributor.

**Authorized Taylor Distributor**

**Specifications**

**Electrical**

One dedicated electrical connection is required. See the electrical chart for the proper electrical requirements. Manufactured to be permanently connected. Consult your local Taylor distributor for cord and receptacle specifications as local codes allow.

**Beater Motor**

One, 1.5 hp.

**Refrigeration System**

One, 10,100 BTU/hr. R449A.

**Air-Cooled**

Minimum 6 in. (152 mm) on both sides and place the back of the machine against a wall to prevent recirculation of warm air. Minimum air clearances must be met to ensure adequate airflow for optimum performance. Optional air discharge chute directs heated air exhaust upwards. No clearance required on right side if air discharge chute is used.

**Water-Cooled**

Water inlet and drain connections out rear panel 3/8 in. FPT.

**Options**

- Cart with casters-height to top of hopper cover: 59-5/8 in. (1,515 mm)
- Cone Dispenser
- Decals - Vanilla or Flavor Burst Cone
- Hopper Locks
- Legs (increase height of unit by 4-1/4 in. [108 mm])
- Syrup Rail (front mount requires special cart with rear door)
- Syrup Rail Kit (side mount)
- Top Air Discharge Chute (air-cooled only)

**C201 Cart Weights:**

Net: 150 lb. (68.0 kg) Crated: 171 lb. (77.6 kg) 14.5 cu. ft. (0.41 cu. m)