

C713



Soft Serve Freezer - Two Flavour 'Twist', Gravity



ITEM No. _____

Model options:

C713/1A Soft Serve Freezer (single phase)

C713/3A Soft Serve Freezer (three phase)

(AIR cooled as standard, water cooled units are available on request)

Standard equipment:

- Hopper agitators
- 1x Starter kit sanitiser sachets
- 1x White cleaning bucket
- 1x Tube Taylor foodsafe lubricant
- 1x Set Taylor cleaning brushes
- 1x Replacement tune up kit
- 12 Months parts & labour warranty

Optional extras:

- Panel spinner for shakes
- Hopper locks
- Built-in syrup rail (factory order)
- Extended service contract (call for details)

Features:

Offer all the popular soft serve variations from 'Whippy style' low or non-fat ice creams to custards, yogurt, sorbet and vegan desserts. Serve two separate soft serve flavours, or an equal combination of both in a twist.

- ♦ **Freezing Cylinder** - Two, 3.2 litre
- ♦ **Hourly Production**** - 78.22 litres combined (approximately)
- ♦ **Mix Hopper** - Two, 18.9 litre. Separate hopper refrigeration (SHR) maintains mix below 5°C during Auto and Standby modes.
- ♦ **Indicator Lights** - Digital readout displays hours since last brush cleaning to assure product safety. Mix Low light alerts operator to add mix. Audible alarm may be enabled to sound when mix is low. When the Mix Out light flashes, the unit shuts down automatically to prevent damage.
- ♦ **Touch Screen Controls** - Microprocessor touch controls are embedded in durable tempered glass panel. Multiple languages are selectable. Viscosity is continually measured to dispense consistent quality soft serve desserts. Temperatures in the hoppers or freezing cylinders may be displayed at any point of operation. Draw counter allows operator to view number of servings dispensed.
- ♦ **Standby** - During long no-use periods, the standby feature maintains safe product temperatures in the mix hopper and freezing cylinder.
- ♦ **Two Locking Casters** - Front casters have a locking feature for operators to keep equipment in place. The lock can be released to move the equipment for cleaning.
- ♦ **Door Interlock System** - Protects the operator from injury as the beater will not operate without the dispensing door in place.
- ♦ **Freezer Door** - A specially designed thermo-plastic door allows quick ejection of product with a simple movement of the draw handle. Self closing draw handles are standard.
- ♦ **Flavor Burst™ FB80 Compatible** (call for details)

C713



Soft Serve Freezer - Two Flavour 'Twist', Gravity

ITEM No. _____

Section view: (Dimensions shown in brackets in mm)

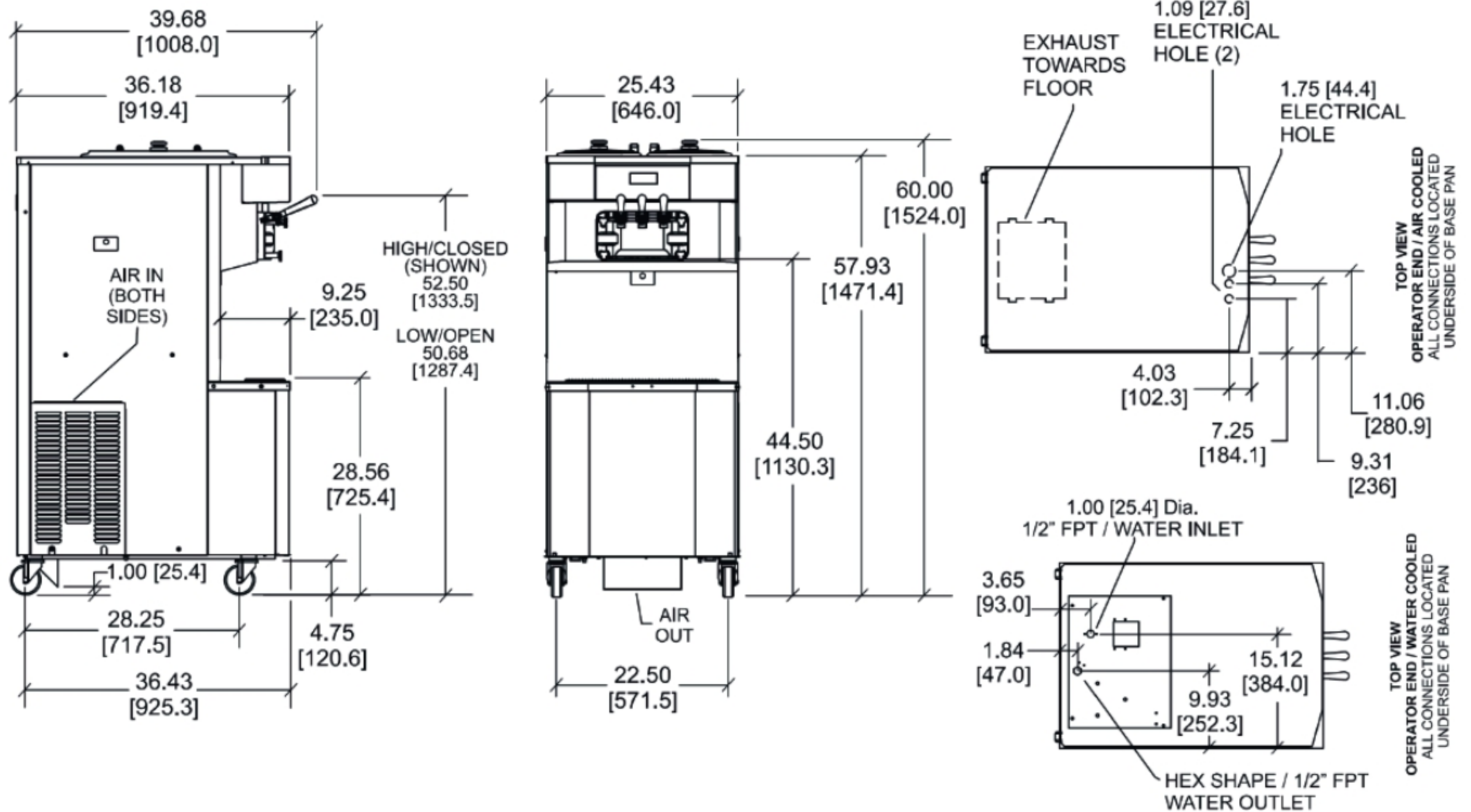

Taylor C713	SINGLE PHASE	THREE PHASE
External dimensions (WxDxH)	646 x 1008 x 1524 mm	
Net weight / crated weight (freezer only)	333 Kg / 368 Kg	
Wall clearance* (sides/back)	100 mm / 0 mm	
Soft serve freezers are NOT designed for built-in installation		
Refrigeration system - Main	2 x 9,500 BTU/hr	
Refrigeration system - Hopper	400 BTU/hr	
Beater motor (No./Power)	2 - 1.5 HP	
Cooling	Air (water cooled available on request)	
Approximate hourly production**	78.22 ltr	
Voltage	230v / 50Hz / 1Ph	400v / 50Hz / 3Ph
Minimum amp draw	21 amps	9 amps per phase
Circuit breaker	32 amp	16 amp
Isolator socket	2x 32 amp (1P+N+E)	32 amp (3P+N+E)
	2X	

*Minimum air clearances **MUST** be met to assure adequate airflow for optimum performance of air cooled machines. Install the deflector provided and place the back of the unit against a wall to prevent recirculation of warm air.

**Hourly production figures are approximate and based on optimum operating conditions. Product type, ambient air temperature and air flow will effect the production capacity.

•A dedicated power supply is required for safe operation. Taylor equipment should never be operated on any form of extention lead, please consult a qualified electrician for correct installation advice.